



flawless fusion with infinite possibilities

SIFAM
F I B R E O P T I C S



Multimode Power Combiner with PM Signal Feedthrough

SIFAM's TFB series Power Combiners provide a high efficiency means of combining light from several multimode sources into one fibre.

SIFAM proprietary manufacturing techniques allow the precise fusion of input fibres around a central PM (polarisation maintaining) signal feedthrough fibre and a PM dual clad output fibre providing high coupling efficiency over a wide pump wavelength range.

Available in a standard (6+1)x1 configuration, the combiner can be fabricated from a range of industry standard fibres for ease of splicing to commercially available laser diodes and fibre applications.

Custom variants using non-standard fibres are available on request.

Please contact the sales team for further information.

Key Features:

- 1.5 μ m & 1.0 μ m PM Signal fibres available
- All fibre construction
- High power design
- High Coupling Efficiency
- PM Axis maintained
- Custom configurations available

Applications:

- Cladding pumped fibre lasers
- Cladding pumped fibre amplifiers
- Telecoms
- Medical
- Industrial
- Defence

SIFAM Fibre Optics Ltd
Broomhill Way, Torquay
Devon TQ2 7QL
England



Certificate No. 0962231

Tel: +44(0) 1803 407784
Fax: +44(0) 1803 407786
sales@sifamfo.com
www.sifamfo.com

Optical Specifications₁

Parameter	Specification	Unit	
Pump Input Fibre NA	0.15	0.22	-
Pump Input Wavelength	900 to 1000		nm
Signal Input Wavelength	1064 or 1550		nm
Pump (MM) Transmission Efficiency ₂	≥ 90 (Typ > 95)	≥ 90	%
Signal Transmission Efficiency ₃	≥ 80 (Typ > 85)		%
Signal PER (Polarisation Extinction Ratio)	>20		dB
Return Loss/Directivity	>40		dB
Operating Temperature	0 to +75		°C
Storage Temperature	-40 to +85		°C

1. All specifications are for operation at room temperature.
2. MM Transmission efficiencies based on typical system mode fill conditions and 0.5m pigtailed. Reported at 975nm as standard.
3. Signal (feedthrough) transmission efficiency reported at centre wavelength; specification typical for centre wavelength ±15nm (minimum).

Ordering Code Information

Example: TFB-P50611B70 (6+1x1 Tapered Fibre Bundle with PM 1550nm signal feedthrough, six 105/125um 0.15NA pump inputs, one 1550nm core DCF Output in high power housing with 0.5m pigtailed).

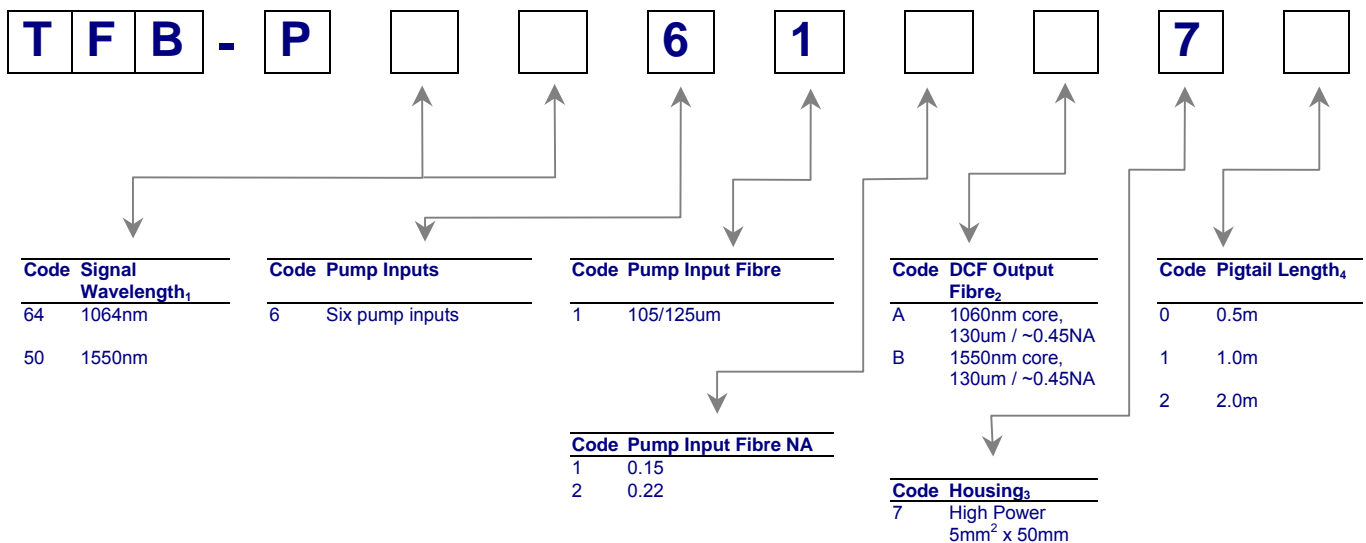

1. Signal wavelengths of 1064nm or 1550nm assume the use of Nufern PM-980-HP and PM-1550-HP (or equivalent) signal feedthrough fibres respectively.
2. Typical mode field diameter is based on ~6.2um for 1064nm fibre and ~10.5um for 1550nm fibre. All fibres are passive.
3. Maximum housing lengths shown. Adequate heat-sinking is required for high power operation. For more information please contact the SIFAM sales team.
4. Minimum pigtail lengths.