



flawless fusion with infinite possibilities

SIFAM
F I B R E O P T I C S

Near Infrared WDM



The Near Infrared WDM enables the low loss combining or splitting of a pair of wavelengths within the 700nm to 1150nm region. SIFAM can rapidly produce such custom WDMs, with typical minimum wavelength separation of 50nm.

Designed for applications in fibre laser, sensing, biomedical, military and avionics the WDM utilises SIFAM's low loss fused fibre technology. No light leaves the fibre and therefore no alignment is required. Furthermore the output fibre pigtails may be directly integrated into beam delivery systems.

Specific applications could include combining two sensor wavelengths onto one fibre, splitting laser harmonics, or combining wavelengths in fibre lasers.

For components which split optical signals of the same wavelength within the near infrared region please refer to the datasheet 'Near Infrared Coupler'.

Key Features:

- 700 to 1150nm operation
- Custom wavelength capability
- 50nm minimum wavelength spacing (<50nm channel spacing available on request)
- Low loss
- High power handling
- Custom product

Applications:

- Fibre lasers
- Sensors
- Biomedical equipment
- Avionics
- Military
- Research

SIFAM Fibre Optics Ltd
Broomhill Way, Torquay
Devon TQ2 7QL
England



Certificate No. 0962231

Tel: +44(0) 1803 407784
Fax: +44(0) 1803 407786
sales@sifamfo.com
www.sifamfo.com

Optical Specifications

Channel Spacing	Available Housing	Max Insertion Loss _{1,2,3}	Min Isolation ₃
100 – 50nm	3,4,5	0.5dB	12dB
>100nm	3,4,5	0.4dB	14dB

1. In 2x2 components insertion loss is not specified for launch through second input port P4 (coloured blue)
2. Maximum insertion loss at operating wavelength. Not including TDL, PDL or connector losses.
3. Improved specifications may be available- contact Sales Department.

Parameter	Specification	Unit
Operating Wavelength	Specified wavelength within the range 700-1150nm	nm
Operating / Storage Temperature Range ₁	-40 to +75 / -40 to + 85	°C
Pigtail Tensile Load	5	N
Fibre Type	Speciality singlemode fibre	

1. For connectorised component, operating temperature range is -5 to +75°C.

Housing Option

Housing Code	Description	1x2, 2x2 Dimensions (mm)	Pigtail
3	Regular	3.0 (Ø) x 60 (L)	Primary-coated fibre
4	Ø0.9 mm slim	3.0 (Ø) x 70 (L)	Ø 0.9mm loose-tube
5	Ø 0.9 mm semi-ruggedised	5.0 (Ø) x 85 (L)	Ø 0.9 mm loose-tube

Configuration



SIFAM Fibre Optics Ltd
Broomhill Way, Torquay
Devon TQ2 7QL
England



Certificate No. 0962231

Tel: +44(0) 1803 407784
Fax: +44(0) 1803 407786
sales@sifamfo.com
www.sifamfo.com

Ordering Code Information

FFW-780060130 (Fused Fibre WDM, 780/1060, 1x2, Regular Housing, 1m pigtails, No connectors)

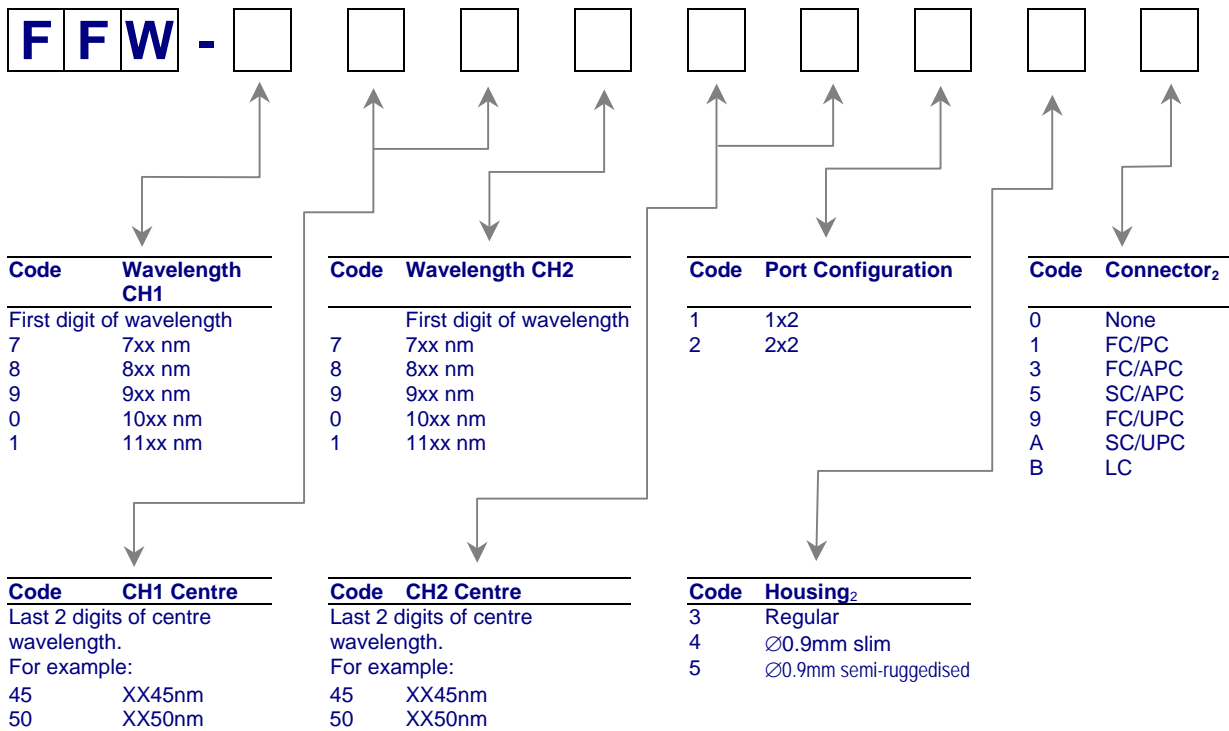

1. 1m Pigtail length as standard. For custom pigtail length requirements please contact the sales office.
2. Connectors may be fitted to housing types 4 and 5. For connectorisation of housing type 3 please contact the sales office.

