



flawless fusion with infinite possibilities

SIFAM
FIBRE OPTICS

Ultra Low Ratio Tap Coupler



The Ultra Low Ratio Tap Coupler splits a very small amount of light from a signal path to a tap port.

Tested at up to 50W optical power, it's main application is in the monitoring of very high power optical sources such as fibre lasers. Low tap ratios such as 0.1%, 0.01% or 0.001% enable the monitoring photodetector to operate without damage or saturation.

SIFAM proprietary manufacturing technology provides ultra-low loss in the signal path, thereby maximising optical power handling. Consistently high return loss (>55dB) reduces the amount of optical power reflected back along the input fibre. This helps the fibre laser operate in a stable manner.

Standard parts are available for wavelengths from 700 to 1599nm. For other wavelengths, coupling ratios or customised fibre types please contact the sales office.

Key Features:

- Tested up to 50W optical power
- Tap ratio from 0.001%
- Ultra-low signal insertion loss
- High return loss
- Available at wide variety of laser wavelengths
- Customised fibre types available

Applications:

- Fibre Lasers
- RAMAN amplifiers
- High Power EDFA

SIFAM Fibre Optics Ltd
Broomhill Way, Torquay
Devon TQ2 7QL
England



Tel: +44(0) 1803 407784
Fax: +44(0) 1803 407786
sales@sifamfo.com
www.sifamfo.com

As part of our policy of continuous product improvement we reserve the right to change specifications at any time

Certificate No. 0962231

PEC0108 Rev 2

Specifications

Parameter	Specification			Unit
	0.1	0.01	0.001	
Coupling Ratio	0.1	0.01	0.001	%
Tap Insertion Loss	30 (±3)	40 (±4)	50 (±5)	dB
Signal Insertion Loss ^{1,2}	0.1			dB
Return Loss	≥ 55			dB
Operating Wavelength ³	Any selected wavelength from 700 to 1599nm			nm
Housing	Regular Ø3.0 x 50			mm
Operating Temperature	-40 to 75			°C
Storage Temperature	-40 to 85			°C
Pigtail Tensile Load	5			N
Fibre Type ⁴	Singlemode			

1. Maximum insertion loss at operating wavelength. Not including TDL or PDL.
2. In 2x2 couplers insertion loss is not specified for launch through second input port P4 (coloured blue)
3. Other wavelengths available as custom components. Please contact the sales office.
4. For customised fibre types please contact the sales office.

Configuration



SIFAM Fibre Optics Ltd
 Broomhill Way, Torquay
 Devon TQ2 7QL
 England



Tel: +44(0) 1803 407784
 Fax: +44(0) 1803 407786
 sales@sifamfo.com
 www.sifamfo.com

Ordering Code

Examples:

FFS-080 P32 A10 (Fused Fibre Speciality Coupler, 1080nm, 0.001% coupling ratio, regular housing, 2x2, A grade, 1m pigtails, no connectors)

FFS-550 M32 A10 (Fused Fibre Speciality Coupler, 1550nm, 0.1% coupling ratio, regular housing, 2x2, A grade, 1m pigtails, no connectors)

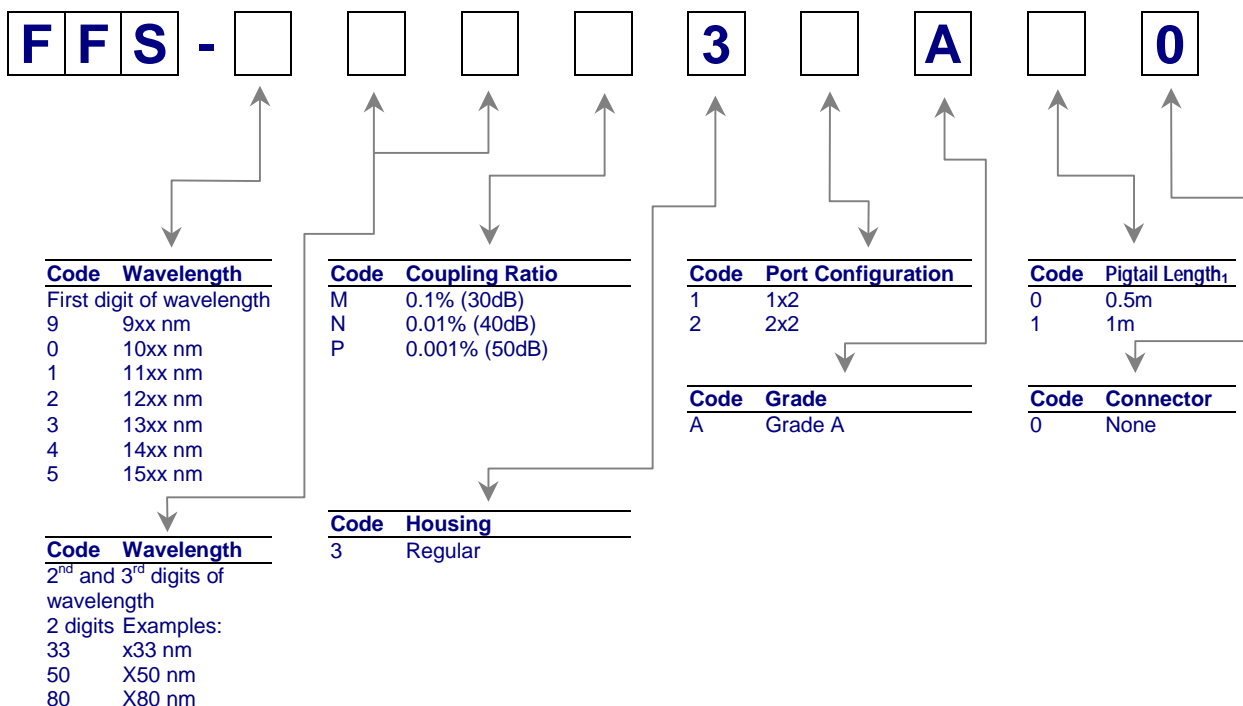

1. Minimum pigtail length. Further pigtail lengths available on request.